

PJP-EC200 Setup Procedure

Yamaha Corporation

Contents

Components	3
When Not Using the Public -Address System	4
Installations and Connections	4
Setup	4
Adjustment	7
When Using the Public -Address System	9
Installations and Connections	9
Setup	9
Adjustment	12

Components

This document explains how to create a webconference environment consisting of the following components.

Microphone	Microphone x 2 Connect to the PJP-EC200 directly.
Speaker	Speakers with built-in amplifier
Public-address system	Enable / Disable
PC	A webconference application should be ready for use. Use microphone input and headphone output jacks for audio input/output. * Microphone and speaker setup for the web conference system on the other end must be done and ready for use.

When Not Using the Public –Address System

Follow the procedure below to output the talker's voice (on your side) only from the speakers in the other end (no output from your side).

* *Italic texts* indicate a procedure which you need to perform using the web menu.

Installations and Connections

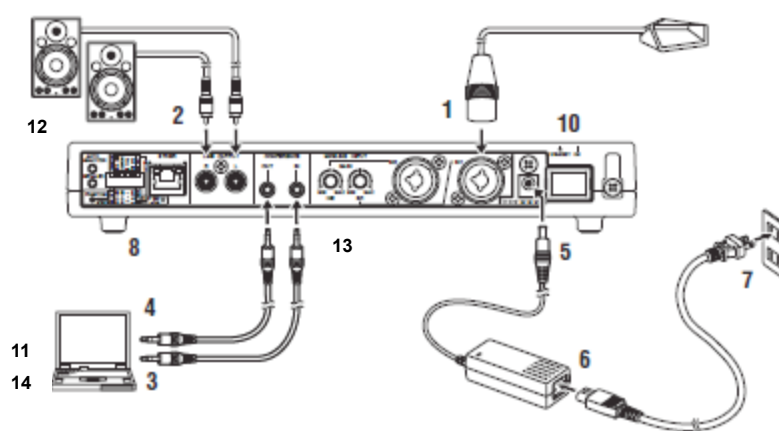

Setup

1. Connect a microphone to MIC/LINE INPUT.
 - 1) Make sure the GAIN level is set to the minimum.
2. Connect speakers with built-in amplifier to LINE OUTPUT.
 - 1) Make sure the speaker volume is set to the minimum.
3. Connect CONFERENCE IN to the headphone output jack of your PC.
4. Connect CONFERENCE OUT to the microphone input jack of your PC.
5. Connect the AC adapter to DC IN.
6. Connect the power cable to the AC adapter.

7. Connect the power cable to an AC outlet.
8. Configure the DIP switch settings.
 - 1) Set the DIP switch ⑥ (SETTING) to “DIP SW” to enable the DIP switch settings.
 - 2) When using a condenser microphone, set the DIP switch ① (PHANTOM) to “ON” to supply 48V power to the microphone.
 - 3) Set the DIP switch ② (IN1 & 2) to “MIC” to select the MIC level for MIC/LINE INPUT.
 - 4) Set the DIP switch ③ (CONF.OUT) to “MIC” to select the MIC level for CONFERENCE OUT.
 - 5) When using a fixed microphone such as a gooseneck microphone and a boundary microphone, set the DIP switch ④ (EC TYPE) to “1” (Echo canceller settings: “Level: 3, Mic Type: Fixed Mic”).
When using a tie-pin microphone or a handheld microphone, set the DIP switch ④ (EC TYPE) to “2” (Echo canceller settings: “Level: 5, Mic Type: Hand Mic”).
 - 6) Set the DIP switch ⑤ (MIX&FS) to “OFF” to disable the public-address system.

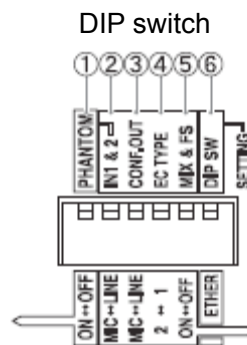

9. Turn on the external devices.
10. Turn on this unit.
11. Adjust the speaker level of your PC or webconference system.
 - 1) Make sure the external device connected to CONFERENCE IN/OUT is

selected as “Default device” in the audio property settings of your PC.

- 2) Make sure the external device connected to CONFERENCE IN/OUT is used in the audio settings of your webconference system.
- 3) Disable the echo canceller and noise reduction functions of your webconference system.
- 4) Turn up the speaker volume.
- 5) While the other end is talking, adjust the speaker output level of your PC or webconference system so that the INPUT LEVEL LED (green) of CONFERENCE IN turns on and the CLIP LED (red) does not turn on.

12. Adjust the speaker volume.

- 1) While the other end is talking, adjust the speaker volume.

13. Adjust the microphone gain of this unit.

- 1) Adjust MIC/LINE IN1.
 - i. While talking into the microphone, use GAIN IN1 to increase the microphone gain gradually.
 - ii. Adjust the microphone gain so that the INPUT LEVEL LED (green) turns on and the CLIP LED (red) does not turn on.
- 2) Adjust MIC/LINE IN2.
 - i. In the same way, adjust the microphone gain for MIC/LINE IN2.

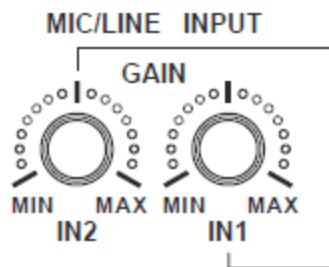

- 3) If the CLIP LED (red) of MIC/LINE IN turns on when the other end’s voice is reproduced from the speakers, use GAIN to decrease the microphone gain or turn down the speaker output level of your PC or webconference system so that the LED does not turn on.

14. Adjust the microphone level of your PC or webconference system.

- 1) Check the current microphone level by using a sound recorder.

- i. Talk into the microphone and then record your voice using a sound recorder on your PC.
 - ii. Play back the recording to check its sound quality and volume. If the sound is distorted (by clip), turn down the microphone volume of your PC. If the volume is extremely low, turn up the microphone volume of your PC.
- 2) Adjust the microphone level of your PC or webconference system.
- i. Adjust the microphone volume of your PC or webconference system to keep the volume of the audio delivered to the other end at a moderate level.

Adjustment

1. Execute the auto analyzer.
 - 1) Press **AUTO ANALYZER** to start the auto analyzer.

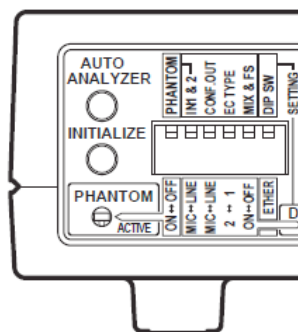

- 2) Wait until the auto analyzer ends. The shortest distance between the speakers and microphone is measured and automatically reflected in the echo canceller settings.
 - * During the measurement, the microphone picks up test tones output from the speakers. To achieve the best result, keep the room as quiet as possible during the measurement.
- 3) If you hear the audio guidance “Normally Completed”, the auto analyzer process (measurement and automatic setup) is properly completed. If you hear any other guidance, adjust the input gain or other settings by following the guidance and then perform the procedures 1) and 2) again.

2. Adjust the echo canceller settings.
 - 1) Ask the other end to check that echoes are not generated after he/she talks. When using a tie-pin microphone or a handheld microphone on your side, keep the microphone moving in the actual conference room and then ask the other end to check that echoes are not generated after he/she talks.
 - 2) If echoes are generated, set the DIP switch ④ (EC TYPE) to “2” (see step 8 in “Setup”) and then ask the other end to recheck.
 - 3) If echoes are still generated, turn down the speaker level of your PC or webconference system or decrease the microphone gain of this unit.

3. *Configure the noise reduction settings.*
 - 1) *To transmit any sounds (voice, environmental sounds, etc.) to the other end, set “MIC/LINE IN1” or “MIC/LINE IN2” of “Noise Reduction” to “Disable”.*
 - 2) *To receive any sounds (voice, environmental sounds, etc.) from the other end, set “CONFERENCE IN” of “Noise Reduction” to “Disable”.*

When Using the Public –Address System

Follow the procedure below to output the talker’s voice (on your side) from the speakers in your side and other end.

- ! We suggest that you use a handheld microphone or a gooseneck microphone. If you use a boundary microphone, acoustic feedback may be frequently generated.

* *Italic texts* indicate a procedure which you need to perform using the web menu.

Installations and Connections

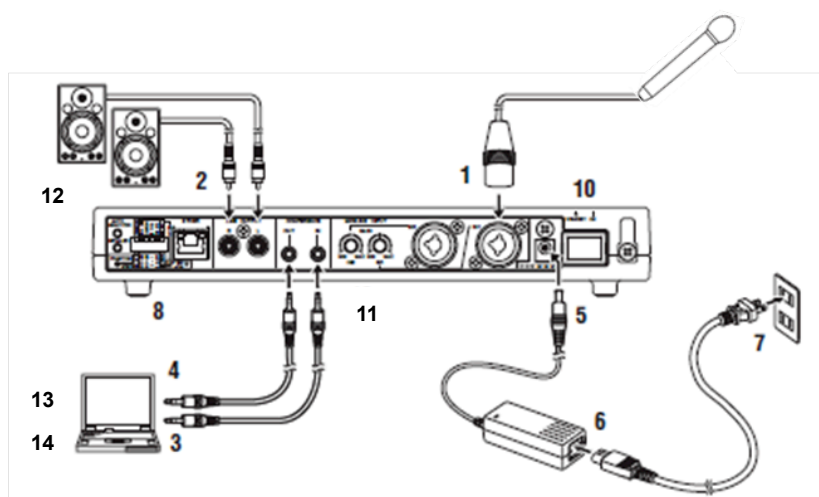

Setup

1. Connect a microphone to MIC/LINE INPUT.
 - 1) Make sure the GAIN level is set to the minimum.
2. Connect speakers with built-in amplifier to LINE OUTPUT.
 - 2) Make sure the speaker volume is set to the minimum.
3. Connect CONFERENCE IN to the headphone output jack of your PC.

4. Connect CONFERENCE OUT to the microphone input jack of your PC.
5. Connect the AC adapter to DC IN.
6. Connect the power cable to the AC adapter.
7. Connect the power cable to an AC outlet.
8. Configure the DIP switch settings.
 - 1) Set the DIP switch ⑥ (SETTING) to “DIP SW” to enable the DIP switch settings.
 - 2) When using a condenser microphone, set the DIP switch ① (PHANTOM) to “ON” to supply 48V power to the microphone.
 - 3) Set the DIP switch ② (IN1 & 2) to “MIC” to select the MIC level for MIC/LINE INPUT.
 - 4) Set the DIP switch ③ (CONF.OUT) to “MIC” to select the MIC level for CONFERENCE OUT.
 - 5) When using a fixed microphone such as a gooseneck microphone and a boundary microphone, set the DIP switch ④ (EC TYPE) to “1” (Echo canceller settings: “Level: 3, Mic Type: Fixed Mic”).
When using a tie-pin microphone or a handheld microphone, set the DIP switch ④ (EC TYPE) to “2” (Echo canceller settings: “Level: 5, Mic Type: Hand Mic”).
 - 6) Set the DIP switch ⑤ (MIX&FS) to “OFF” to enable the public-address system.

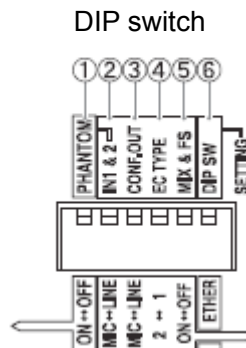

9. Turn on the external devices.

10. Turn on this unit.

11. Adjust the microphone gain of this unit.

1) Adjust MIC/LINE IN1.

- i. While talking into the microphone, use GAIN IN1 to increase the microphone gain gradually.

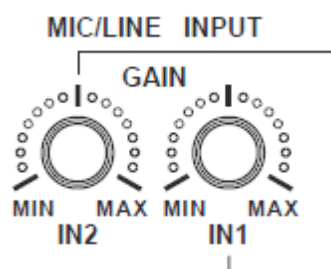

- ii. Adjust the microphone gain so that the INPUT LEVEL LED (green) turns on and the CLIP LED (red) does not turn on.

2) Adjust MIC/LINE IN2.

- i. In the same way, adjust the microphone gain for MIC/LINE IN2.

12. Adjust the speaker volume.

- 1) While talking into the microphone, adjust the speaker volume to a comfortable level so that no acoustic feedback is generated.

13. Adjust the speaker level of your PC or webconference system.

- 1) Make sure the external device connected to CONFERENCE IN/OUT is selected as “Default device” in the audio property settings of your PC.
- 2) Make sure the external device connected to CONFERENCE IN/OUT is used in the audio settings of your webconference system.
- 3) Disable the echo canceller and noise reduction functions of your webconference system.
- 4) While the other end is talking, adjust the speaker output level of your PC or webconference system so that the INPUT LEVEL LED (green) of CONFERENCE IN turns on and the CLIP LED (red) does not turn on.
- 5) Adjust the speaker output level and microphone gain of your PC or webconference system to balance the volumes of other end’s voice with your

voice.

- 6) While sounds are reproduced from the speakers, check that the CLIP LED (red) of MIC/LINE INPUT does not turn on. If the LED turns on, turn down GAIN or speaker output level of your PC or webconference system so that it does not turn on.

14. Adjust the microphone level of your PC or webconference system.

- 1) Check the current microphone level by using a sound recorder.
 - i. Talk into the microphone and then record your voice using a sound recorder on your PC.
 - ii. Play back the recording to check its sound quality and volume. If the sound is distorted (by clip), turn down the microphone volume of your PC. If the volume is extremely low, turn up the microphone volume of your PC.
- 2) Adjust the microphone volume of your PC or webconference system to keep the volume of the audio delivered to the other end at a moderate level.

Adjustment

1. Execute the auto analyzer.
 - 1) Press AUTO ANALYZER to start the auto analyzer.

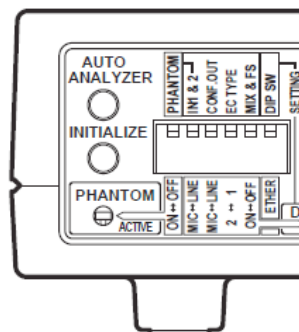

- 2) Wait until the auto analyzer ends. The shortest distance between the speakers and microphone is measured and automatically reflected in the echo canceller settings. Also, the feedback suppressor settings are automatically adjusted to the room environment (automatic environment

learning).

* During the measurement, the microphone picks up test tones output from the speakers. To achieve the best result, keep the room as quiet as possible during the measurement.

- 3) If you hear the audio guidance “Normally Completed”, the auto analyzer process (measurement and automatic setup) is properly completed. If you hear any other guidance, adjust the input gain or other settings by following the guidance and then perform the procedures 1) and 2) again.
2. Adjust the echo canceller settings.
 - 1) Ask the other end to check that echoes are not generated after he/she talks. When using a tie-pin microphone or a handheld microphone on your side, keep the microphone moving in the actual conference room and then ask the other end to check that echoes are not generated after he/she talks.
 - 2) If echoes are generated, set the DIP switch ④ (EC TYPE) to “2” (see step 8 in “Setup”) and then ask the other end to recheck.
 - 3) If echoes are still generated, turn down the speaker level of your PC or webconference system or decrease the microphone gain of this unit.
 3. Configure the feedback suppressor settings.
 - 1) Perform the environment learning of the feedback suppressor.
 - i. Set the microphone gain slightly higher than the threshold level (start of acoustic feedback generation).
 - ii. Acoustic feedback will be repeatedly generated and stopped. If the CLIP LED (red) turns on continuously in the process, decrease the microphone gain to reduce the acoustic feedback generation.
 - iii. If acoustic feedback generation is completely stopped, set the microphone gain to the original level.
 - 2) *If acoustic feedback is still generated, set “Level” of “Feedback Suppressor” to “-18dB” and then perform the procedure 1) again. However, this setting may affect the quality of sounds output through the public-address system.*
 - 3) *In addition, to control acoustic feedback immediately, set “Band width” of “Feedback Suppressor” to “1/60oct”. For more effectiveness, set it to “1/10oct”. However, this setting may affect the quality of sounds output through the public-address system.*

4. *Configure the noise reduction settings.*

- 1) *To transmit any sounds (voice, environmental sounds, etc.) to the other end, set “MIC/LINE IN1” or “MIC/LINE IN2” of “Noise Reduction” to “Disable”.*
- 2) *To receive any sounds (voice, environmental sounds, etc.) from the other end, set “CONFERENCE IN” of “Noise Reduction” to “Disable”.*